

DHF 3: Mark 3 and 4 Assembly

UBCV iGEM 2024

NuCloud



Arduino Microcontroller Bioreactor

Authors:

Matthias Wong - Dry Lab

September 28th, 2024

Index:

1.0 Introduction	3
2.0 Verification	4
2.1 Justifications	4
2.2 Simulation	4
3.0 FMEA - Failure Mode and Effect Analysis	4
4.0 Risk Assessment	4
4.1 Likelihood grading scheme	4
4.2 Severity grading scheme	4
4.3 Justifications for the grading of each hazard	4
Appendix	5

1.0 Introduction

1.1 Background

This is the next design cycle after Mark 2 and is a continuation and upscaling of that design. This mark will have additional features for improved quality-of-life for wet lab members as well as additional components used to help manage bioreactor conditions and measuring them. The vessel will now be upscaled to a 350 mL tissue culture flask commercially available. The goals and needs remain the same as before: to culture E. coli capable of producing thermostable terminal deoxynucleotidyl transferase (TdT/DNTT). This mark is a big step-up from before and finalizes most of the components that are modular for the bioreactor. 2 more sets of rails all standard across the entire base were also added.

2.0 Design

With the introduction of the new vessel, a new base has to be constructed since the tissue culture flask [1] has different dimensions and requires extra space compared to mk.2 for modular components. Additional components include an optical density sensor and a keypad control interface. All designs with “rails” underneath are meant to go on the “tracks” on the side of the base.

2.1 PLA Parts

The following parts are printed using PLA and their files are available in the appendix:

The base:

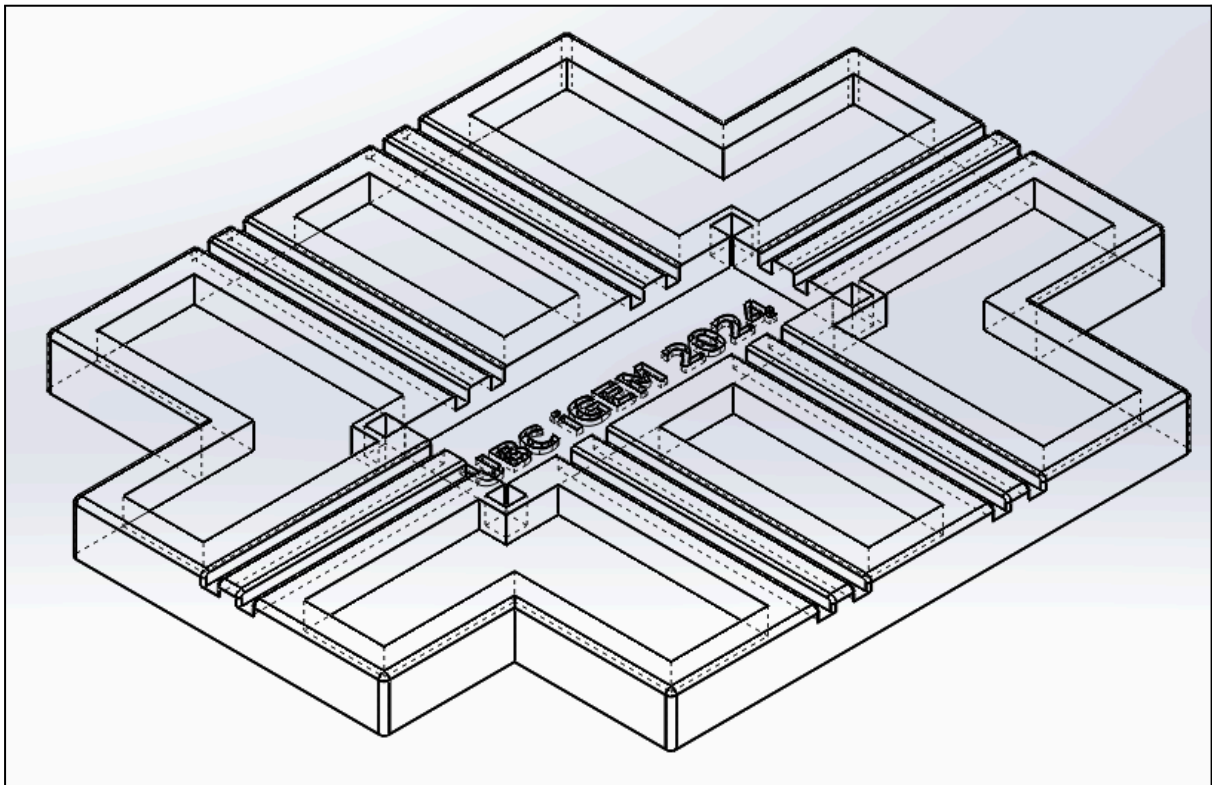

Figure 1: Mk.3 Base with 2 more modular attachments, larger holes for frame and larger central space for flask

The frame:

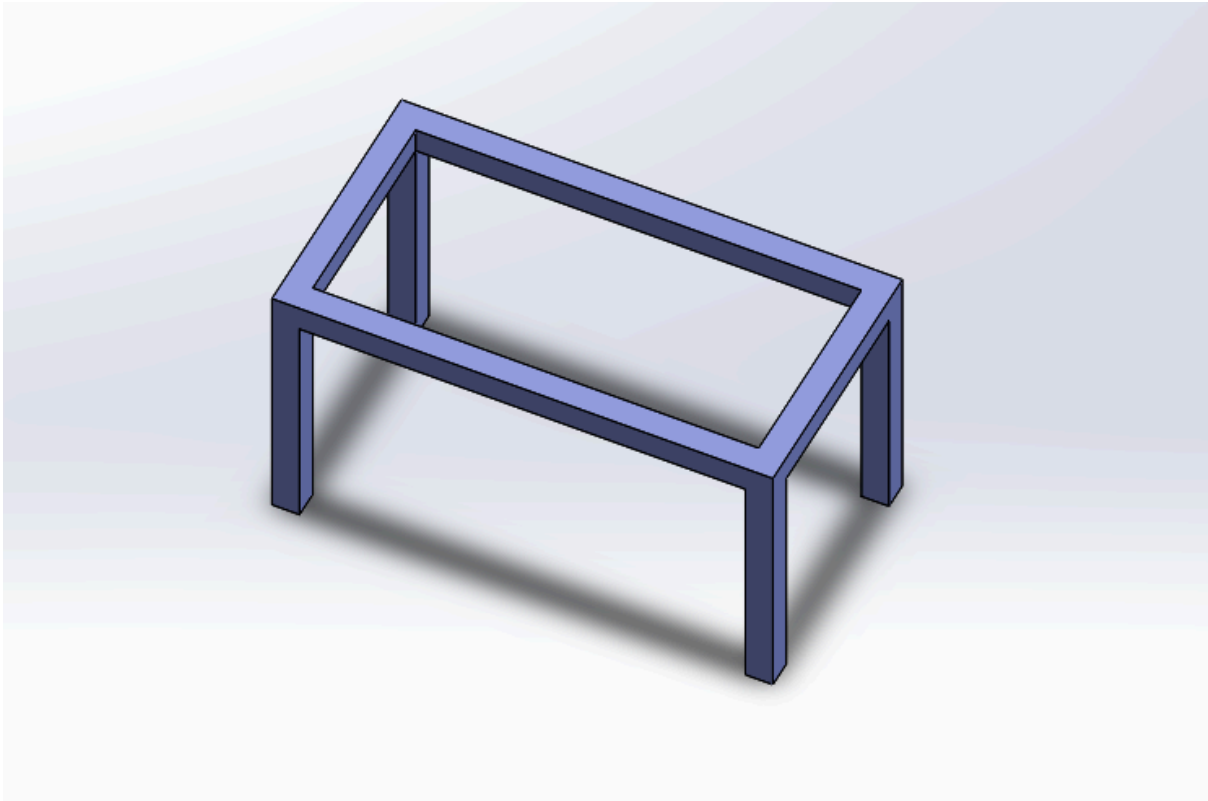

Figure 2: Frame that fits into the base and stabilizes the flask

On-flask module:

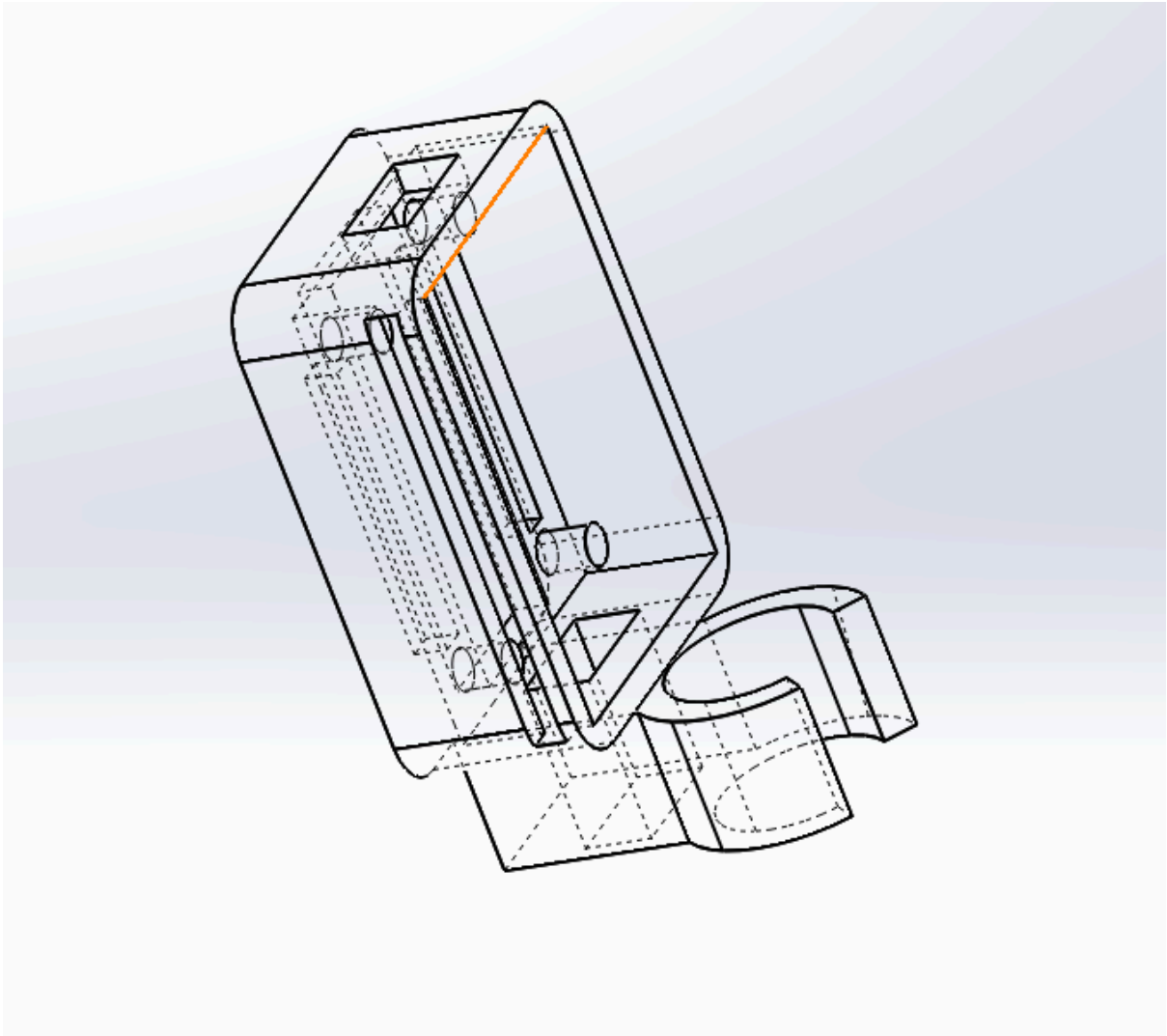

Figure 3:

On-base modules:

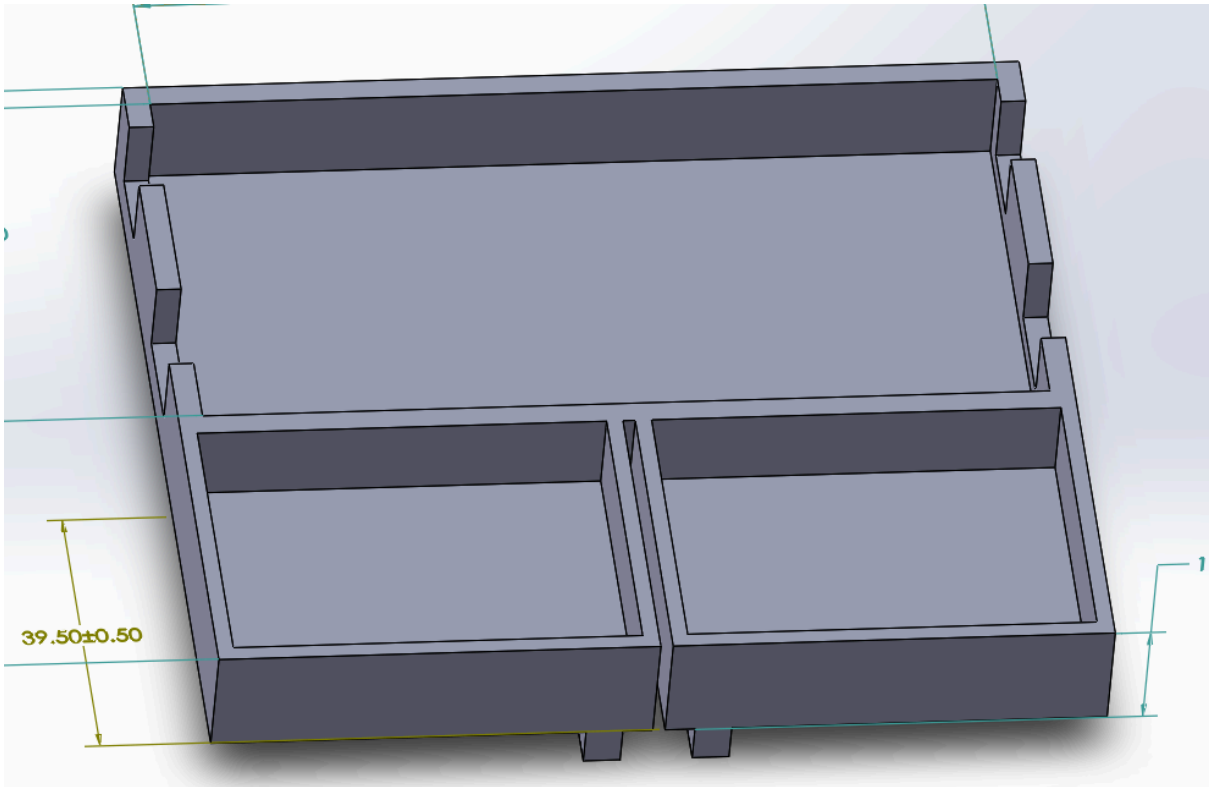

Figure 4: Arduino Mega

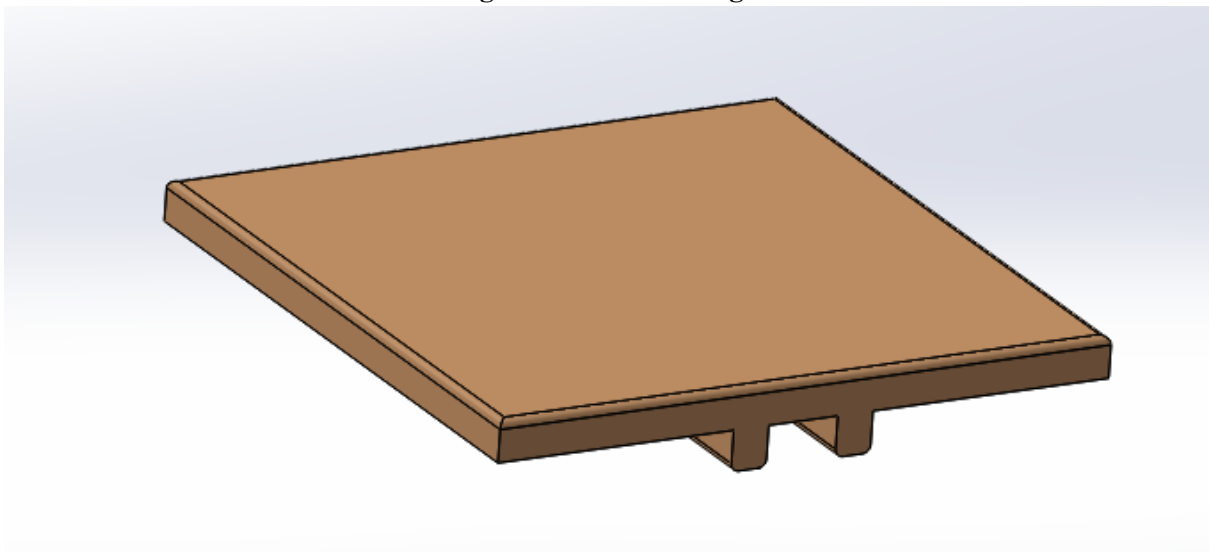

Figure 5: Holder for keypad used to control bioreactor and replaces control panel



Figure 6: LED holder for OD sensor

Appendix

[1]

‘Product - Sarstedt’. Accessed: Sep. 21, 2024. [Online]. Available:

<https://www.sarstedt.com/en/products/laboratory/cell-tissue-culture/cultivation/product/83.3912.502/>

[2]

‘UBC-iGEM/Hardware-2024: Files (STL/SLDPRT/SLDASM) from notion available for public viewing’. Accessed: Sep. 21, 2024. [Online]. Available:

<https://github.com/UBC-iGEM/Hardware-2024>